

# Lavorazioni fresature e forature ante standard per maniglie e cilindri

Agg.22.07.2022

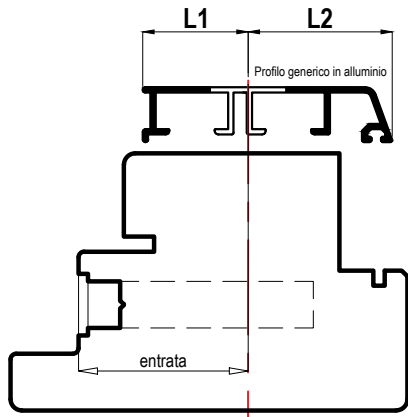

**uniform**  
sistemi per serramenti



L1= \_\_\_\_\_ mm

L2= \_\_\_\_\_ mm

↑ vista interna

VISTA INTERNA  
Internal view  
MONTANTE SX vista interna

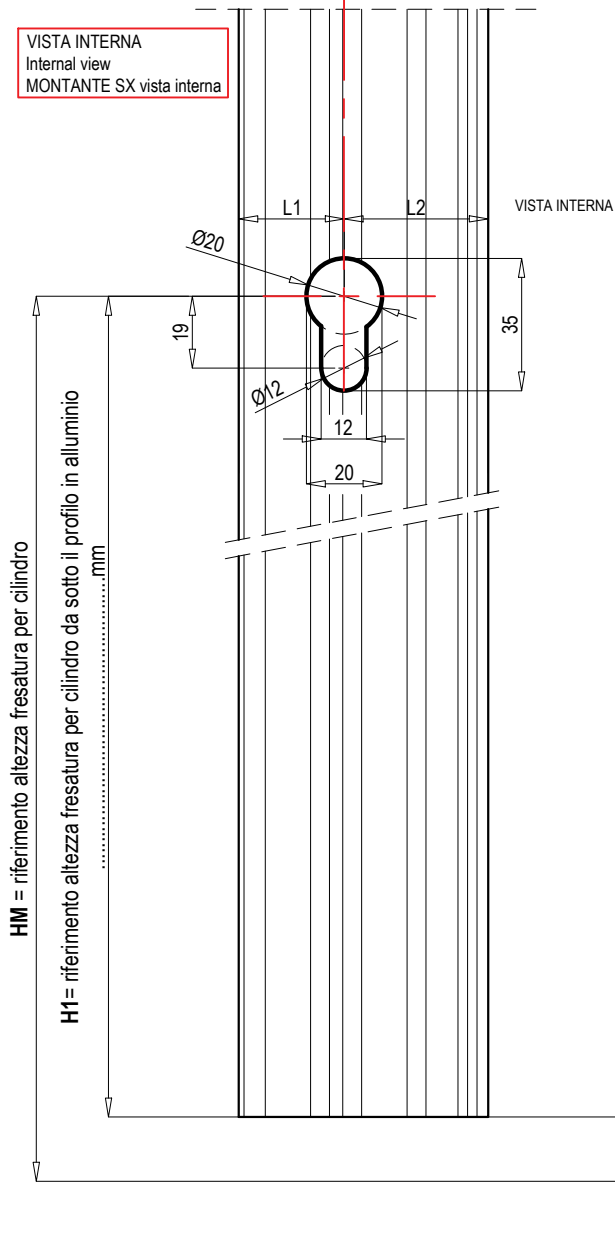

HM = riferimento altezza fresatura per cilindro

H1 = riferimento altezza fresatura per cilindro da sotto il profilo in alluminio

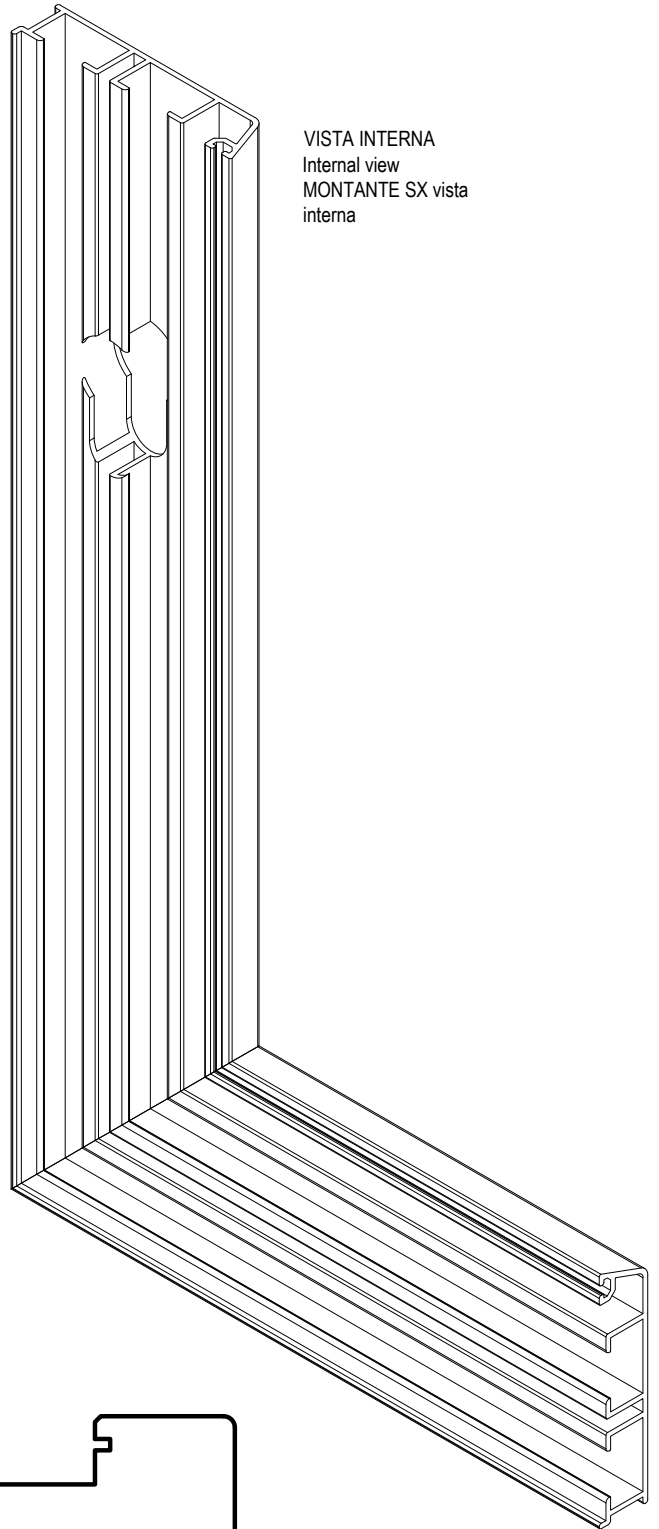
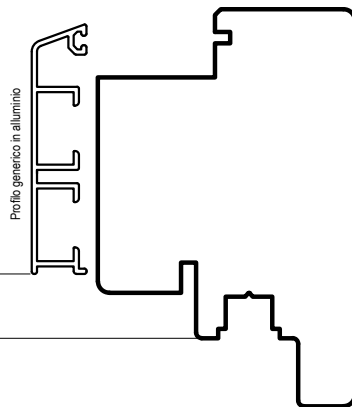

VISTA INTERNA  
Internal view  
MONTANTE SX vista  
interna

Codice lavorazione:

**T015-028SX**

Foratura per cilindro-Sx

VISTA INTERNA  
Internal view  
MONTANTE DX vista  
interna

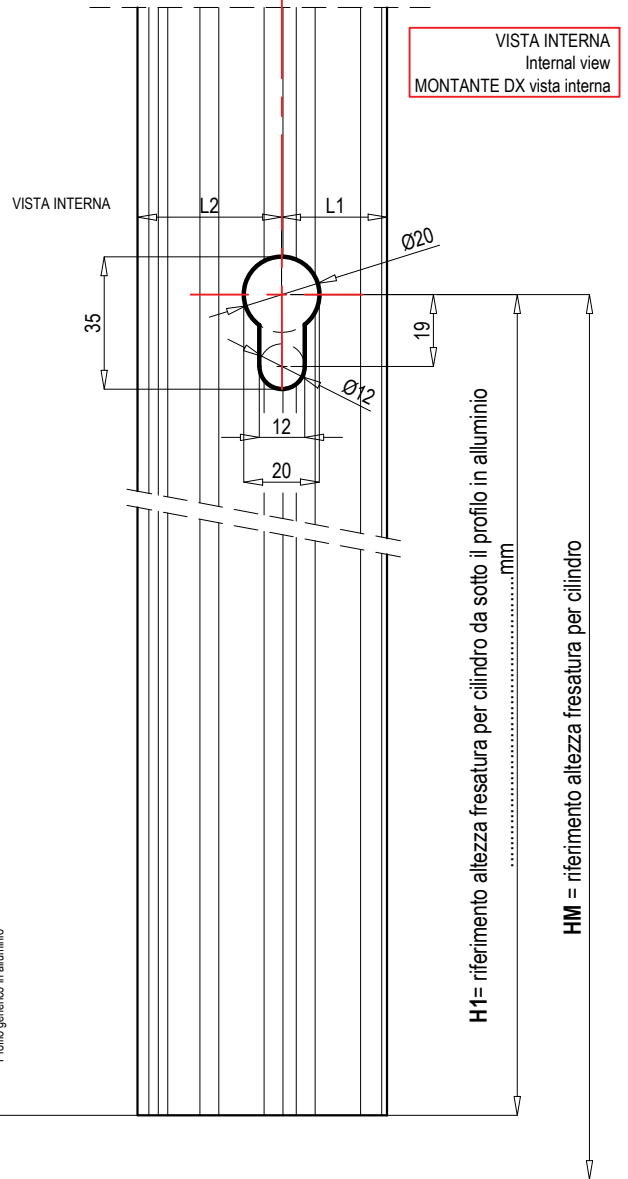
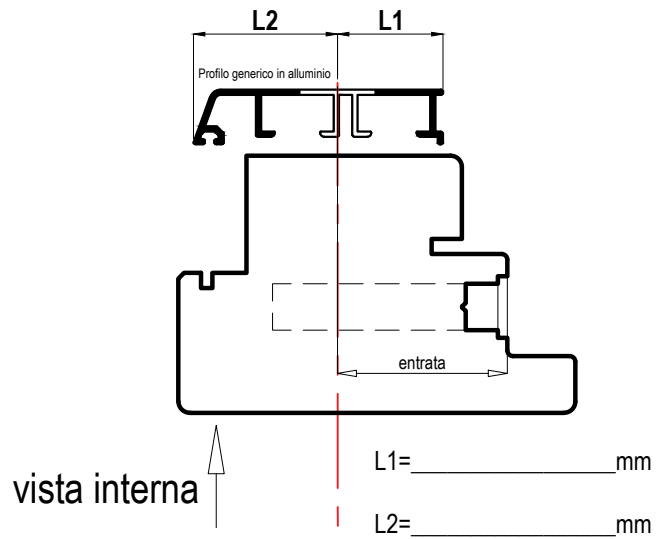
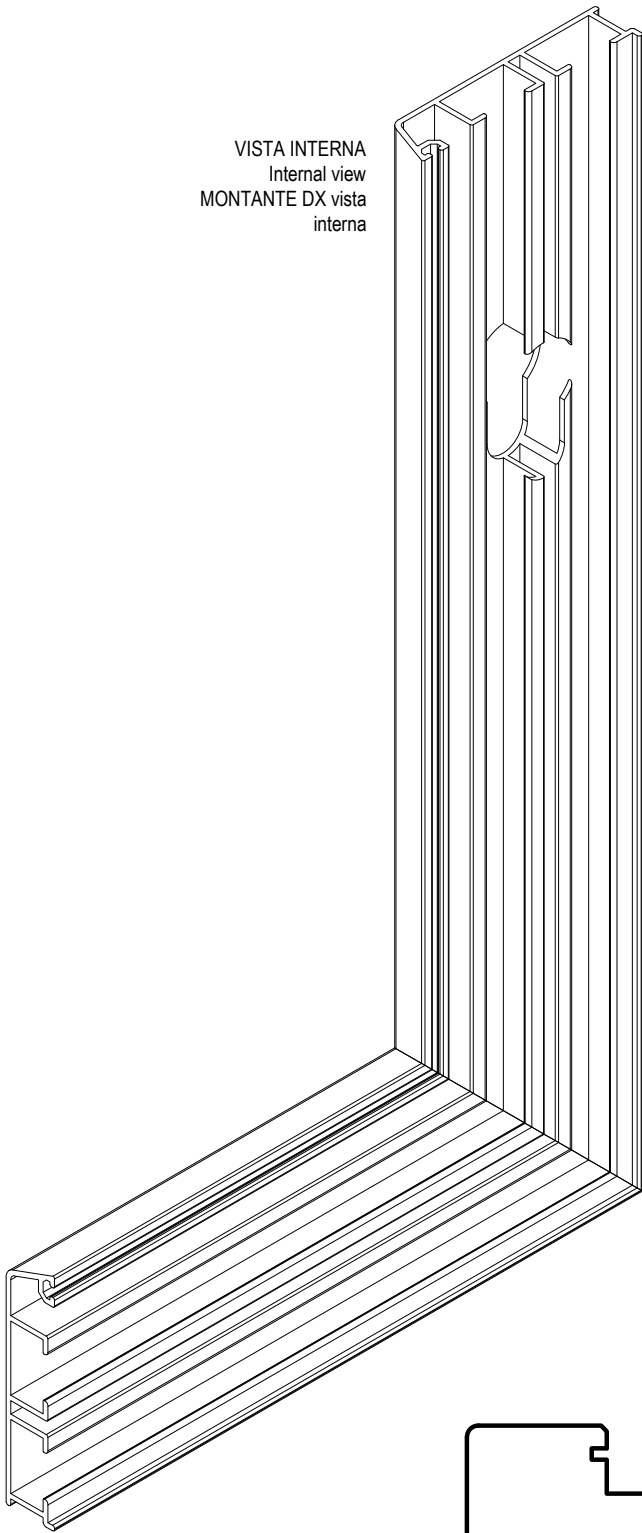

Codice lavorazione:

**T015-028DX**

Foratura per cilindro-Dx

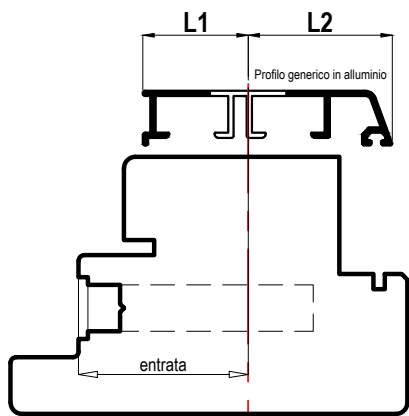

L1= \_\_\_\_\_ mm

L2= \_\_\_\_\_ mm

↑ vista interna

VISTA INTERNA  
Internal view  
MONTANTE SX vista interna

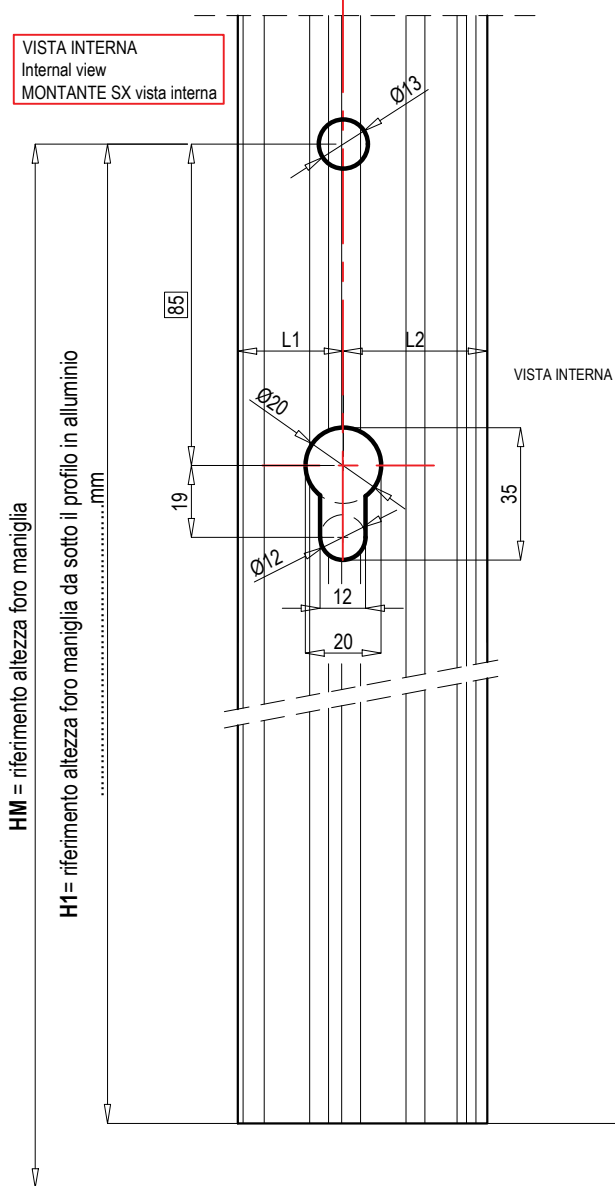

Profilo generico in alluminio

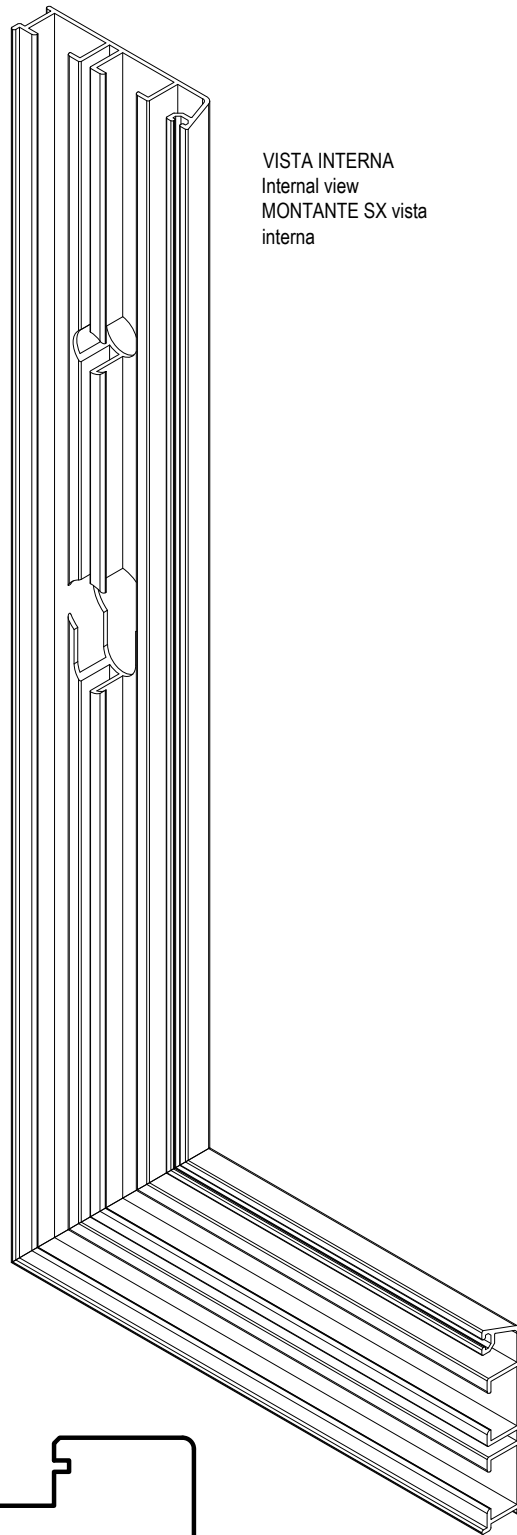

VISTA INTERNA  
Internal view  
MONTANTE SX vista  
interna

Codice lavorazione:

**T015-029SX**

Foratura per maniglia passante e cilindro int.  
85mm -Sx

**uniform**  
sistemi per serramenti

VISTA INTERNA  
Internal view  
MONTANTE DX vista  
interna

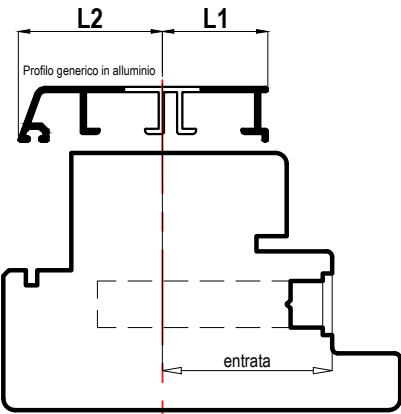
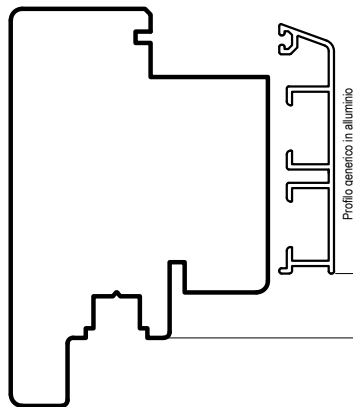
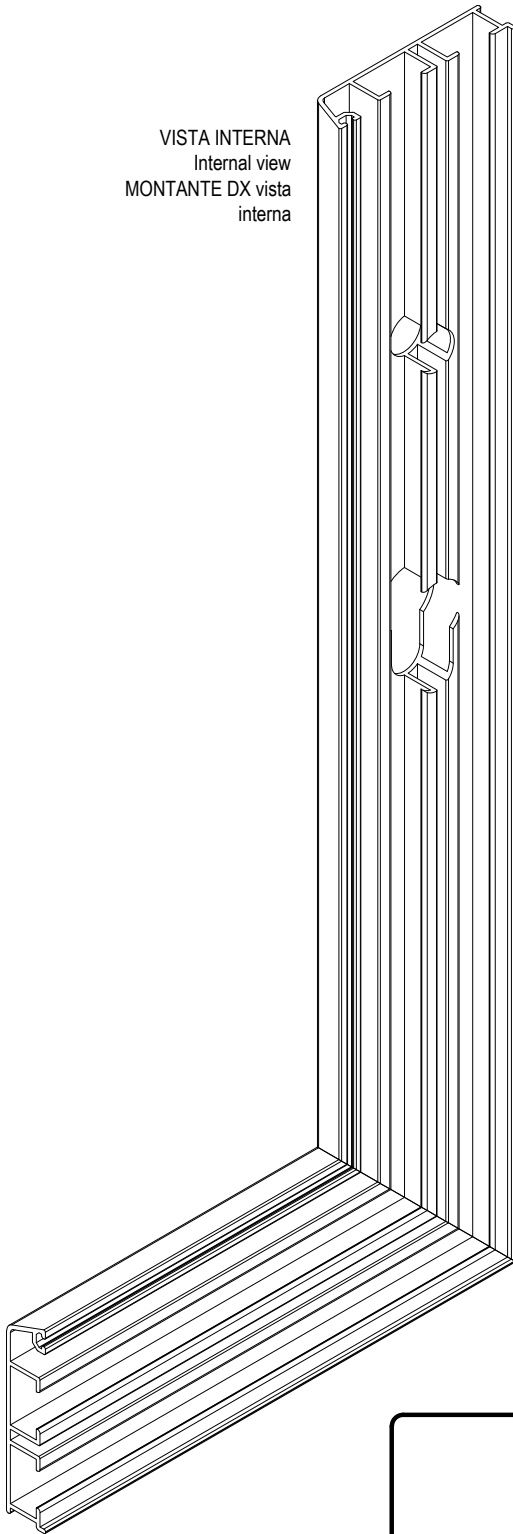

vista interna

L1= \_\_\_\_\_ mm

L2= \_\_\_\_\_ mm

VISTA INTERNA  
Internal view  
MONTANTE DX vista  
interna

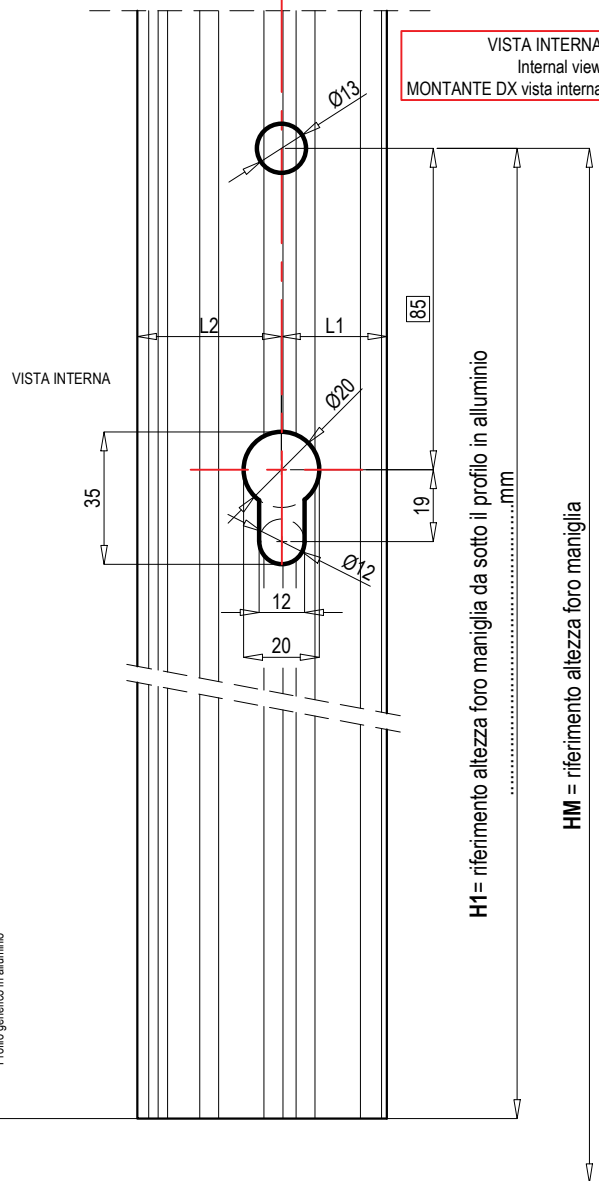

Codice lavorazione:

**T015-029DX**

Foratura per maniglia passante e cilindro int.85mm  
-Dx

**uniform**  
sistemi per serramenti

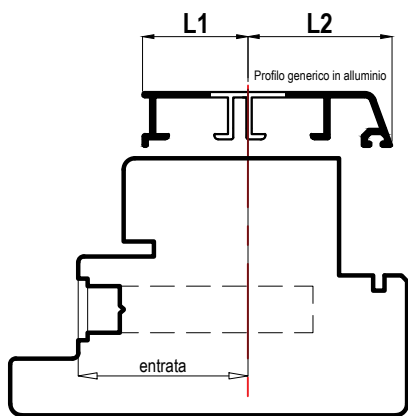

L1= \_\_\_\_\_ mm

L2= \_\_\_\_\_ mm

↑ vista interna

VISTA INTERNA  
Internal view  
MONTANTE SX vista interna

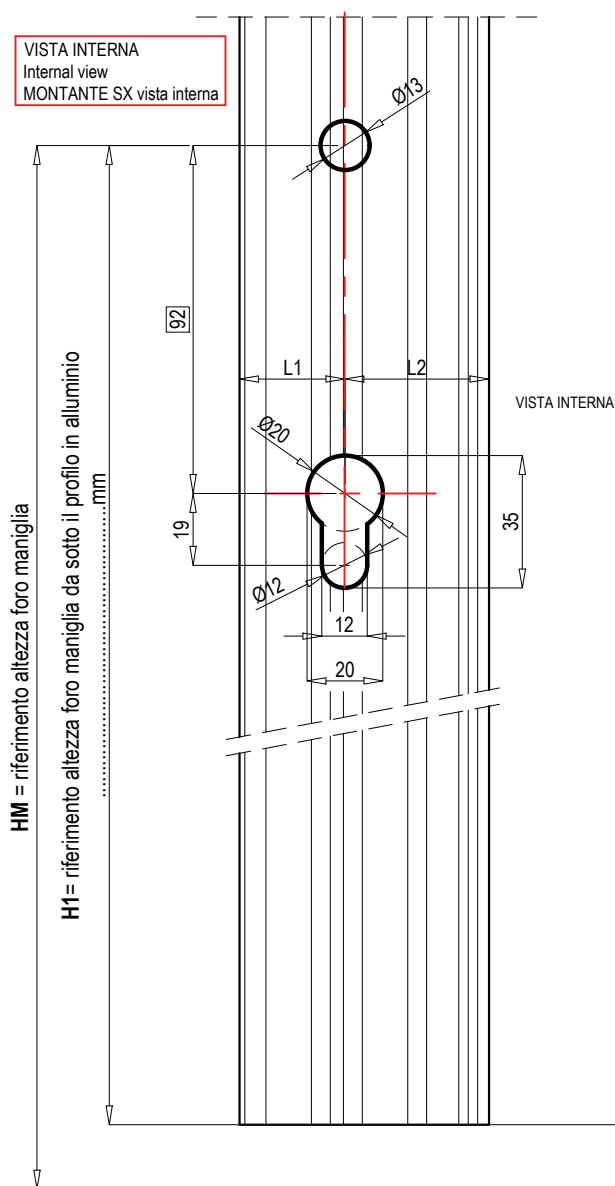

HM = riferimento altezza foro maniglia

H1 = riferimento altezza foro maniglia da sotto il profilo in alluminio

.....mm

VISTA INTERNA

Profilo generico in alluminio

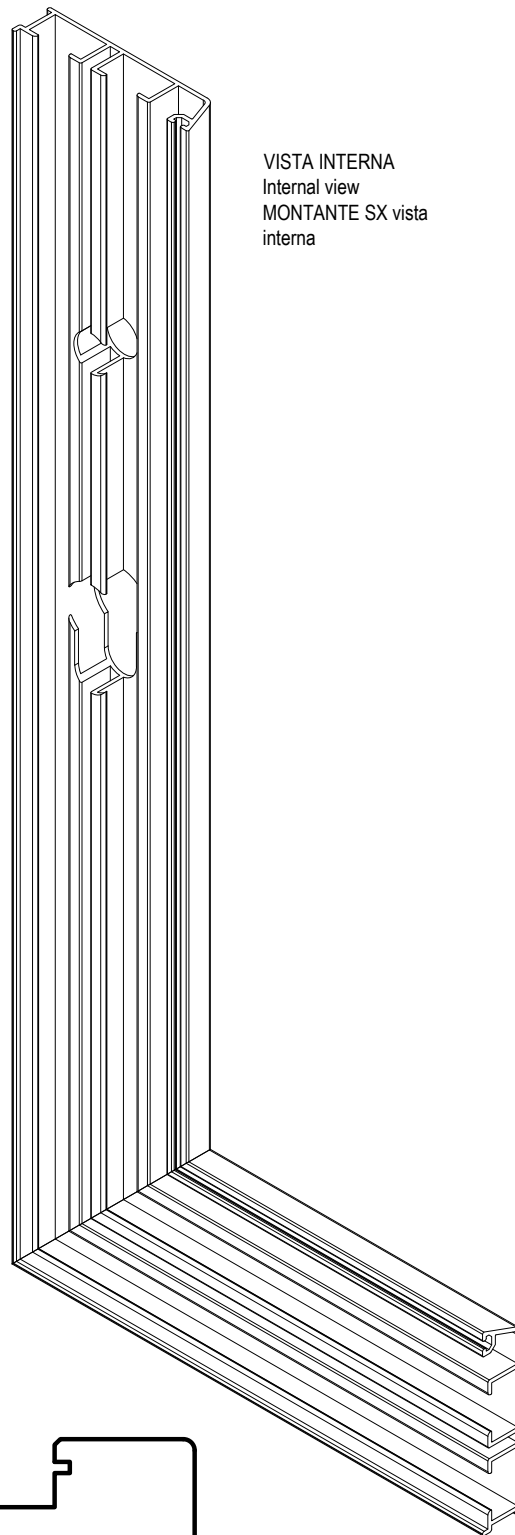

VISTA INTERNA  
Internal view  
MONTANTE SX vista interna

Codice lavorazione:

**P020-101SX**

Foratura per maniglia passante e cilindro int.  
92mm - Sx

VISTA INTERNA  
Internal view  
MONTANTE DX vista  
interna

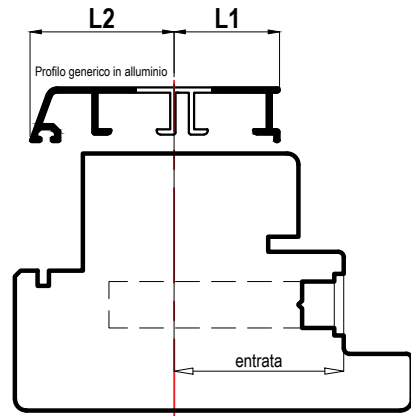
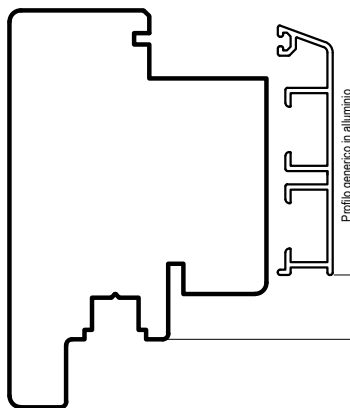
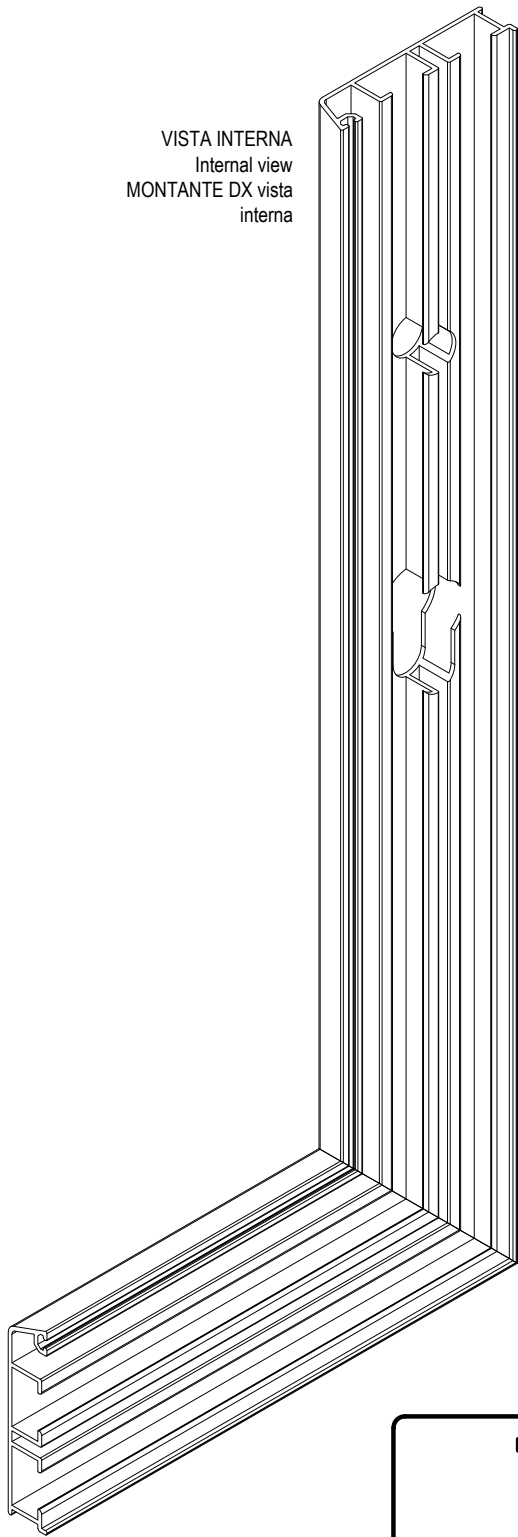

vista interna

L1= \_\_\_\_\_ mm

L2= \_\_\_\_\_ mm

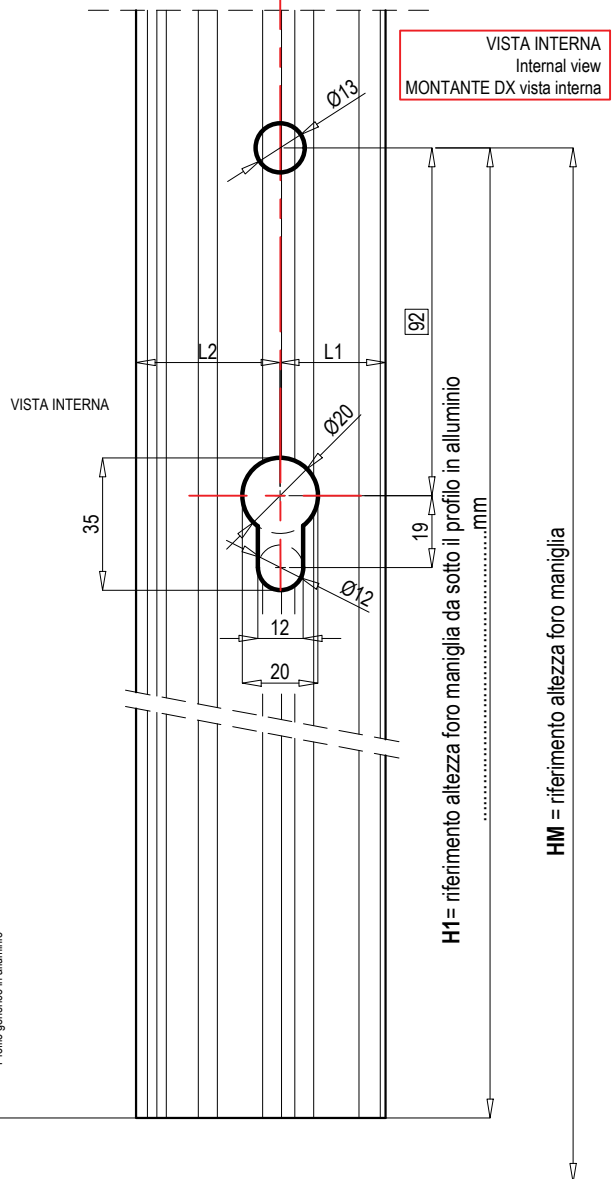

Codice lavorazione:

**P020-101DX**

Foratura per maniglia passante e cilindro  
int.92mm-Dx

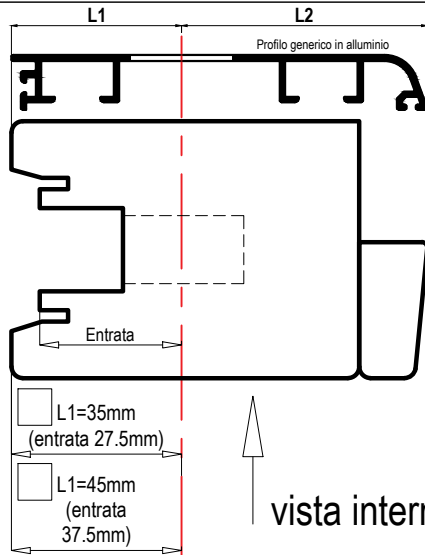

- L1=35mm  
(entrata 27.5mm)
- L1=45mm  
(entrata 37.5mm)

VISTA INTERNA  
Internal view  
MONTANTE SX vista interna

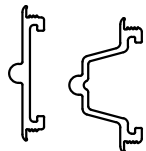
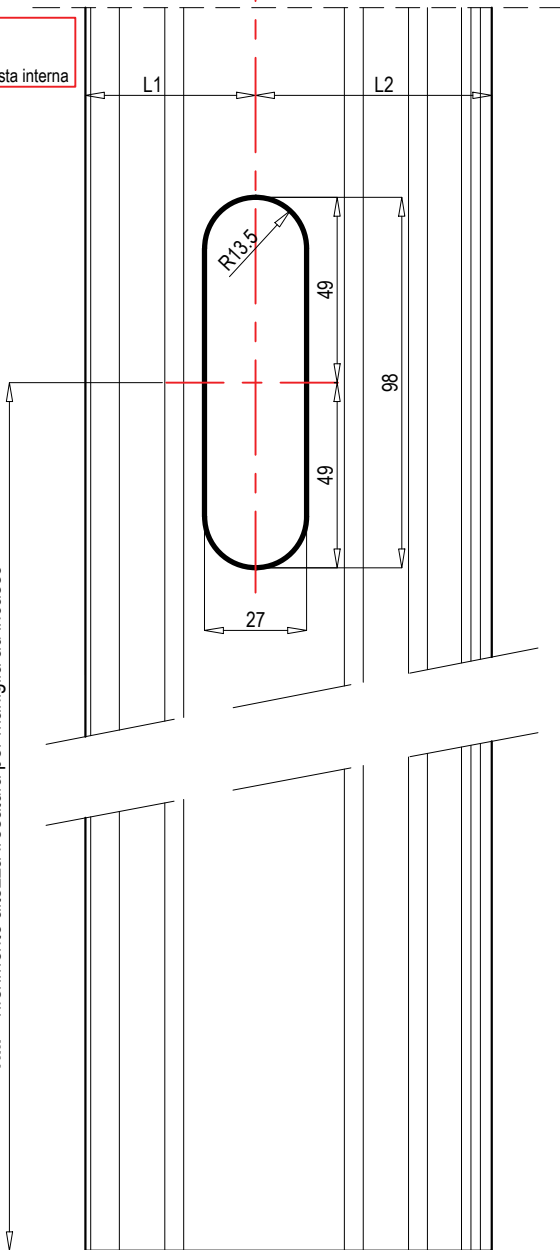

HMM Misure Standard:

- 1000mm con binario basso
- 1010mm con binario alto
- Altro (indicare misura)

HMM = riferimento altezza fresatura per maniglia ad incasso

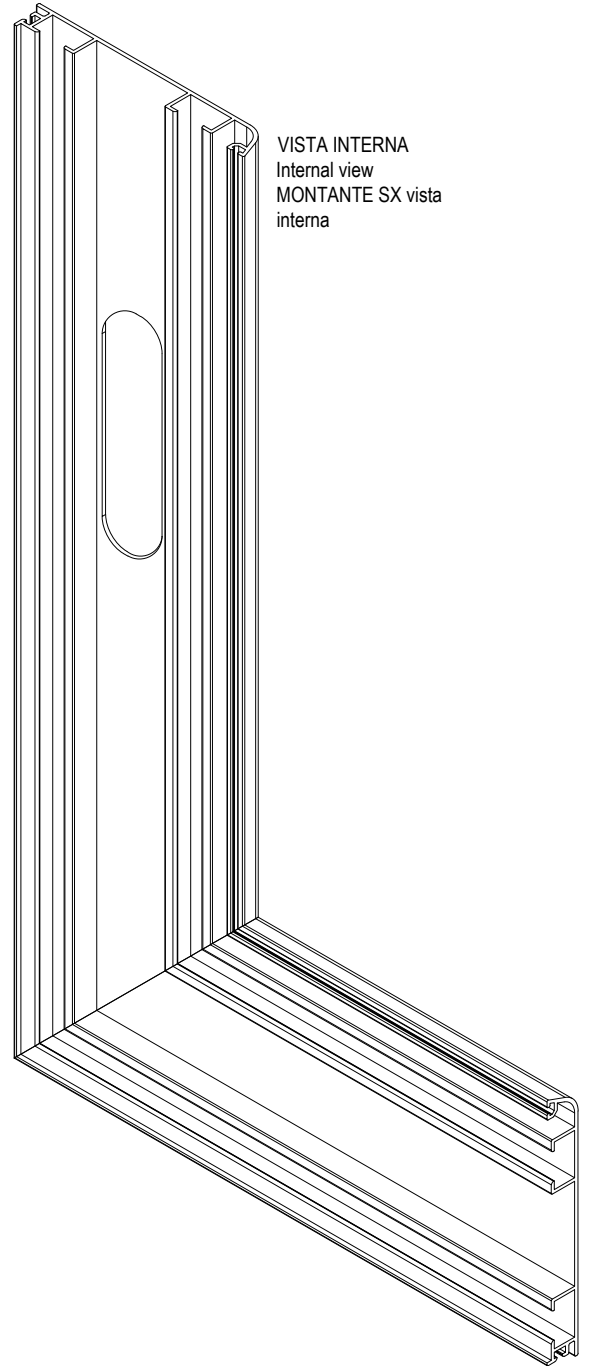

VISTA INTERNA  
Internal view  
MONTANTE SX vista  
interna

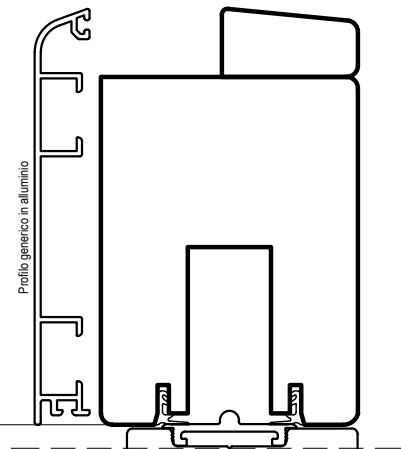

Codice lavorazione:

**T015-030SX**

Foratura per maniglia ad incasso-Sx

**uniform**  
sistemi per serramenti



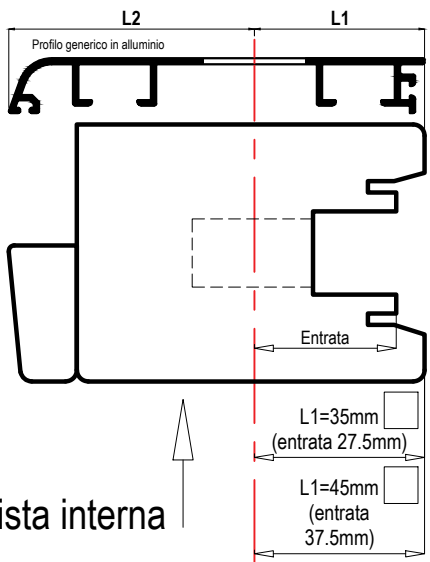

vista interna

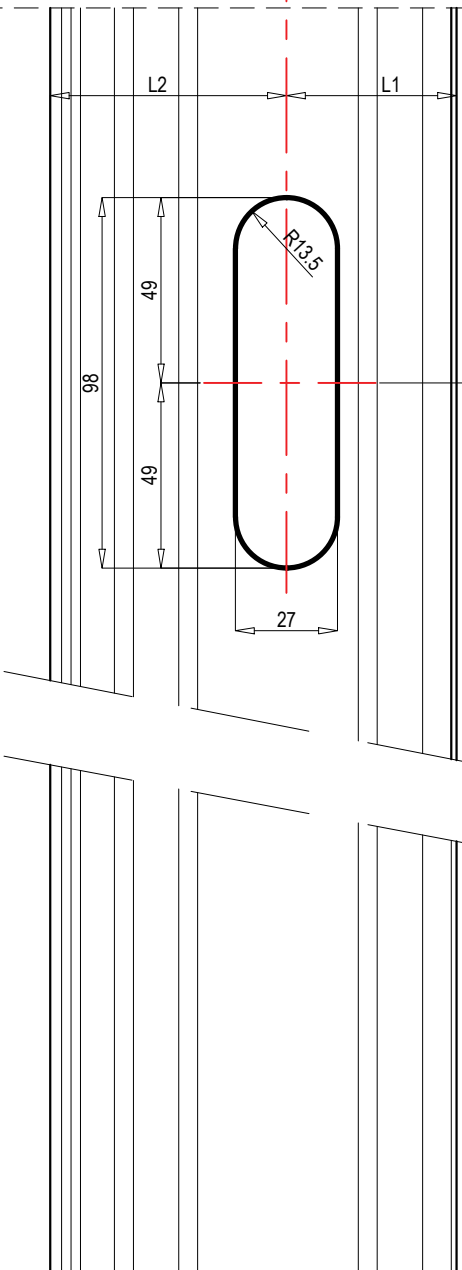

VISTA INTERNA  
Internal view  
MONTANTE DX vista interna

HM = riferimento altezza fresatura per maniglia ad incasso

HM Misure Standard:

- 1000mm con binario basso
- 1010mm con binario alto
- Altro (indicare misura)

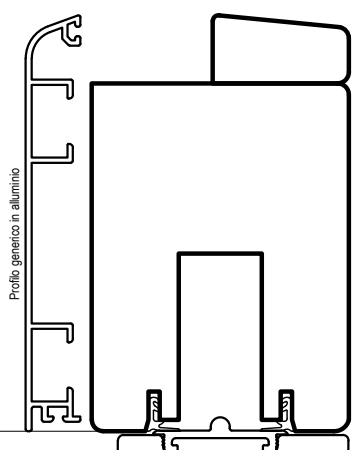
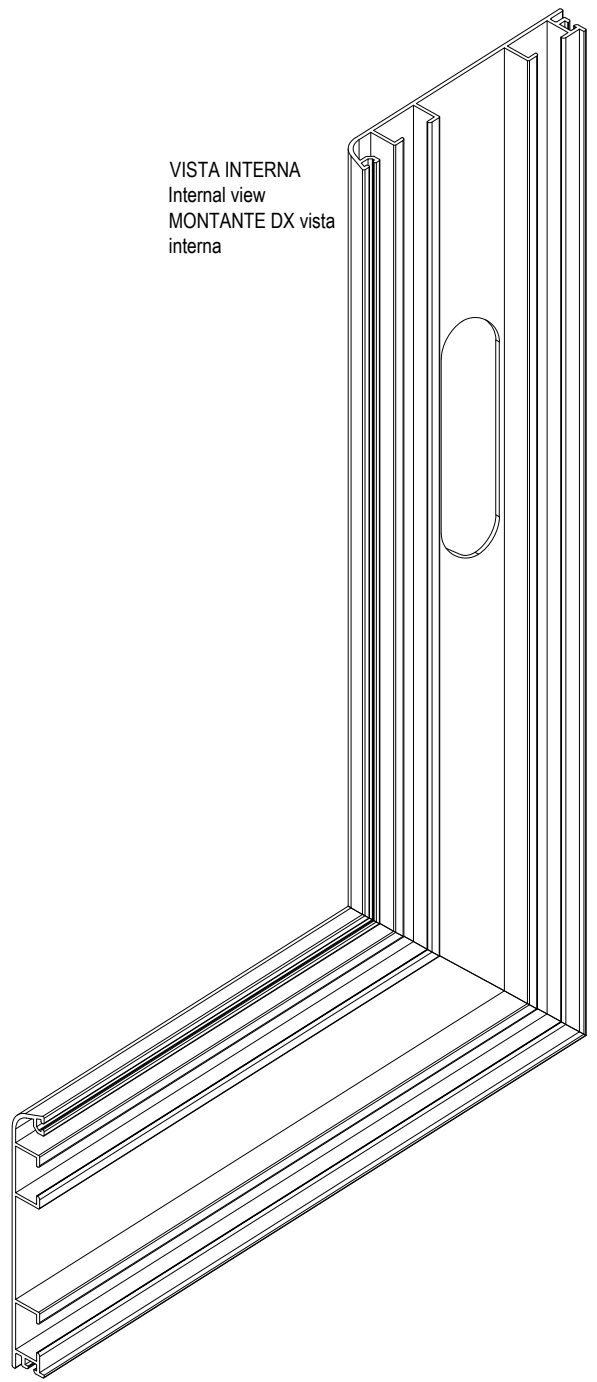

Codice lavorazione:  
**T015-030DX**

Foratura per maniglia ad incasso-Dx

**uniform**  
sistemi per serramenti

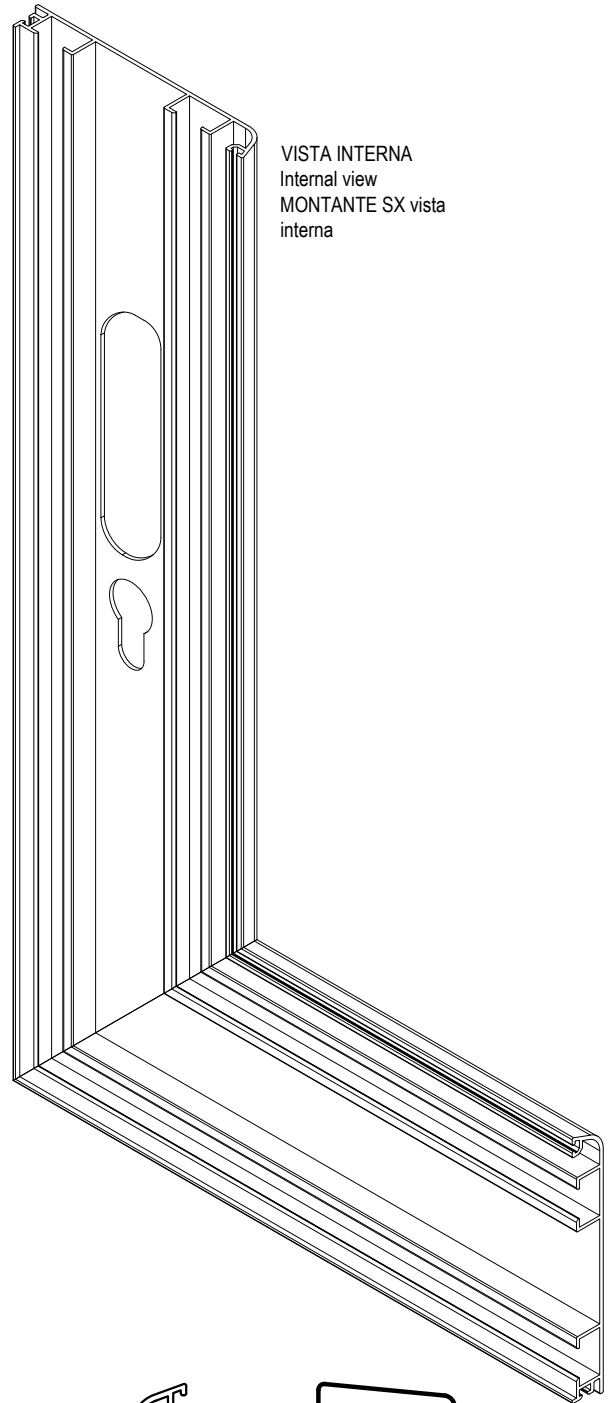
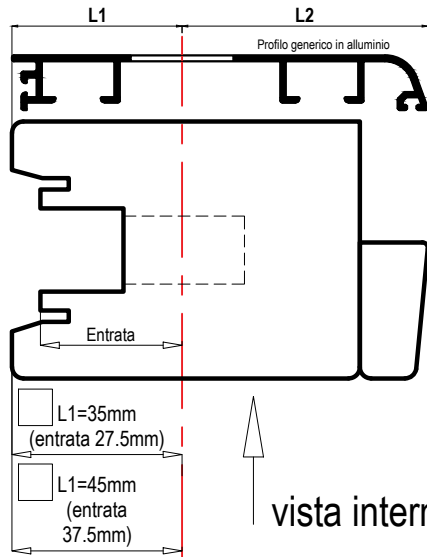

VISTA INTERNA  
Internal view  
MONTANTE SX vista interna

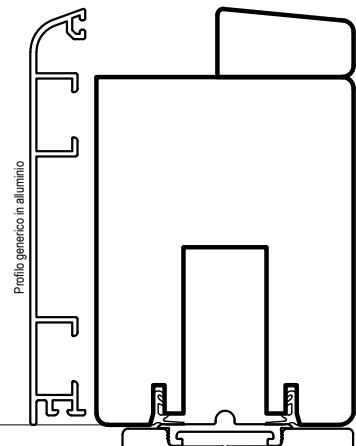
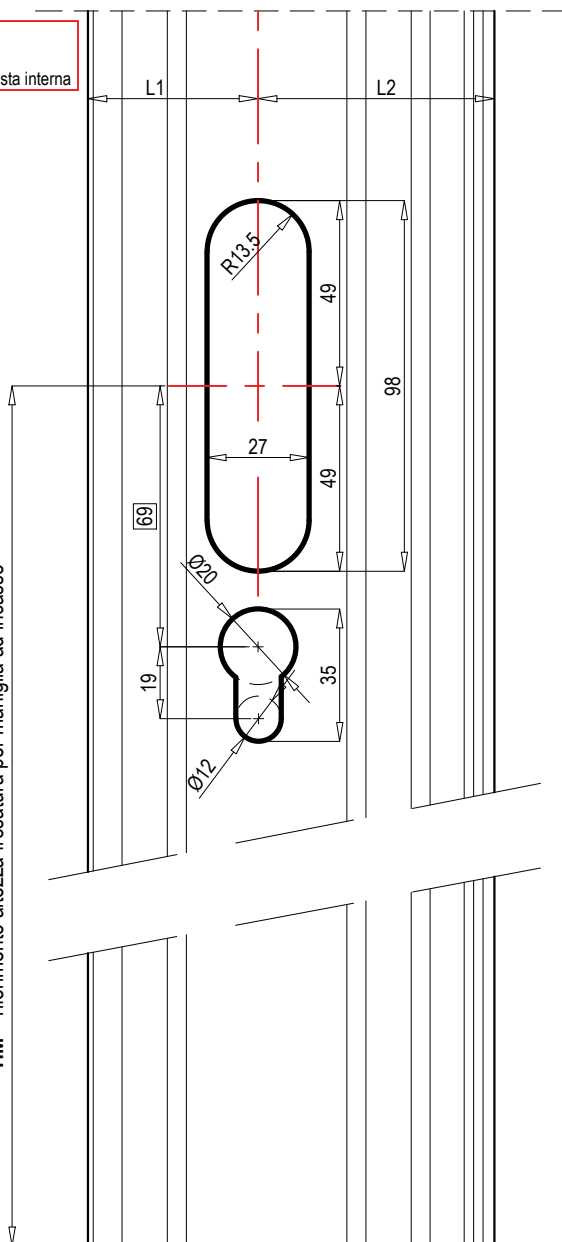

HM Misure Standard:

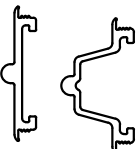

1000mm con binario basso

1010mm con binario alto

Altro (indicare misura)

HM = riferimento altezza fresatura per maniglia ad incasso

Codice lavorazione:

**T015-031SX**

Foratura per maniglia ad incasso e foro cilindro-Sx

**uniform**  
sistemi per serramenti

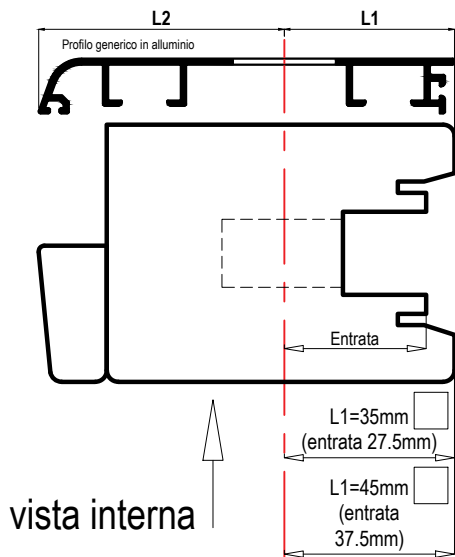

vista interna

VISTA INTERNA  
Internal view  
MONTANTE DX vista interna

VISTA INTERNA  
Internal view  
MONTANTE DX vista interna

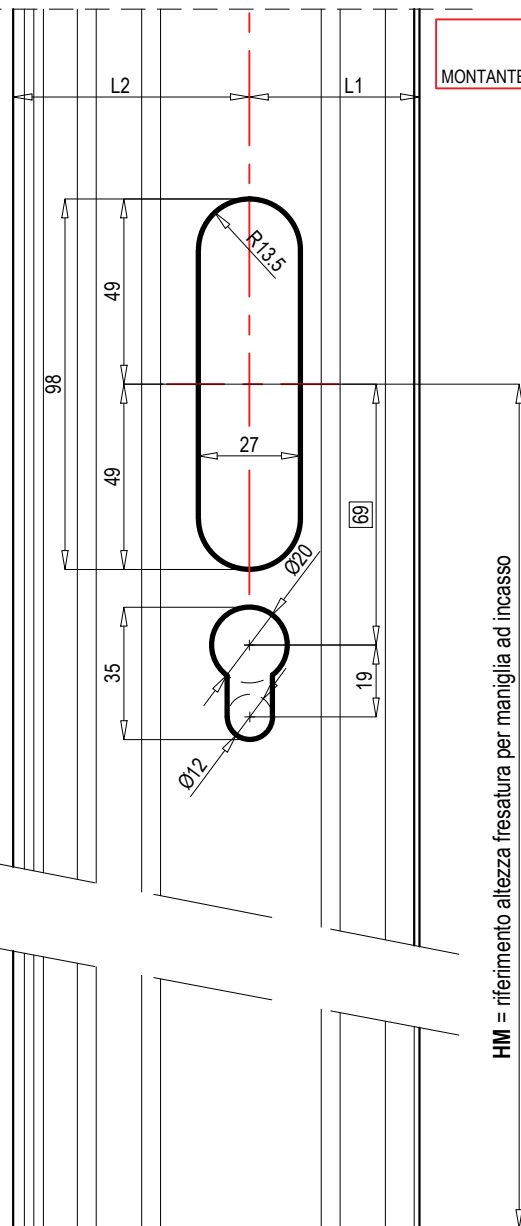
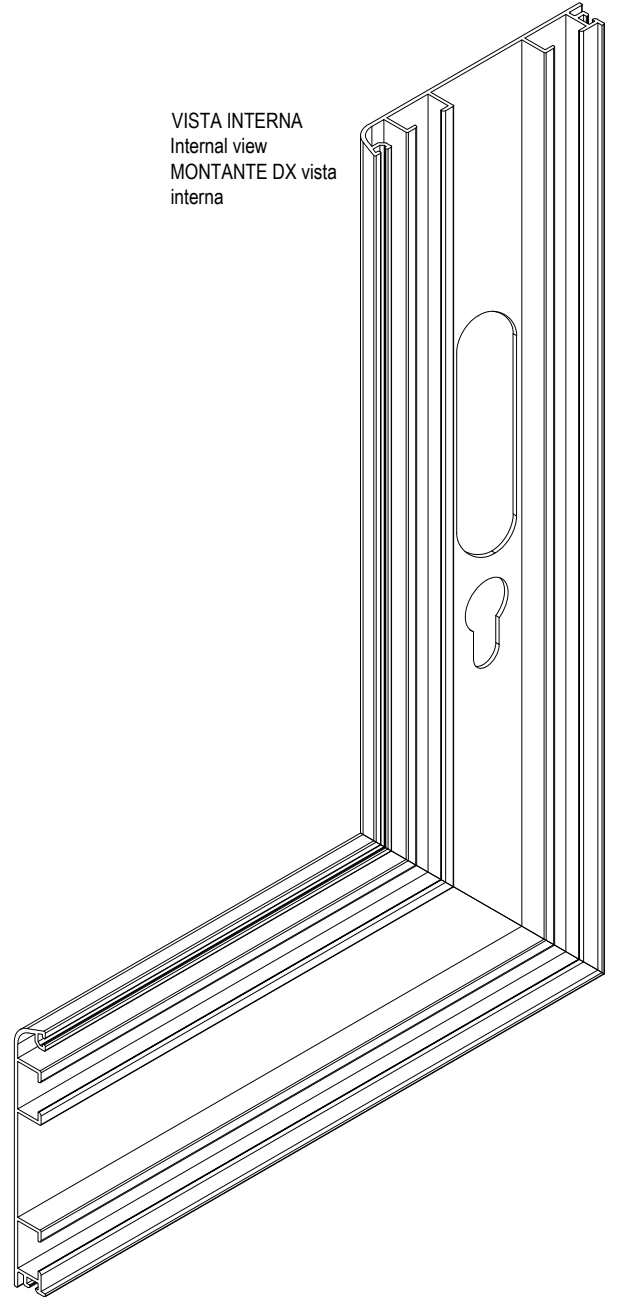

HM = riferimento altezza fresatura per maniglia ad incasso

HM Misure Standard:

1000mm con binario basso

1010mm con binario alto

Altro(indicare misura)

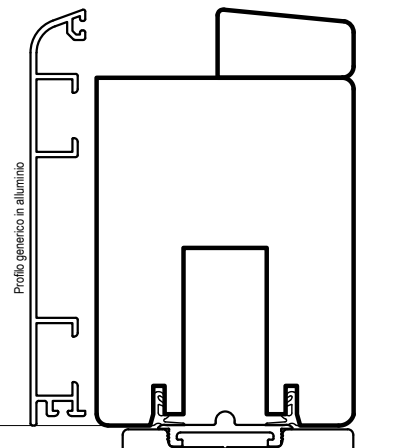

Codice lavorazione:

**T015-031DX**

Foratura per maniglia ad incasso e foro cilindro-Dx

**uniform**  
sistemi per serramenti

Nell'interesse di un continuo miglioramento dei prodotti, Uniform spa si riserva il diritto di variare le specifiche in qualsiasi momento senza previa notifica.

*In the interest of continued improvements to the products, Uniform spa reserve the right to change specifications at any time and without prior notification, and without any obligation*

uniform 